

Fixed Inline Inductor (UL Listed)

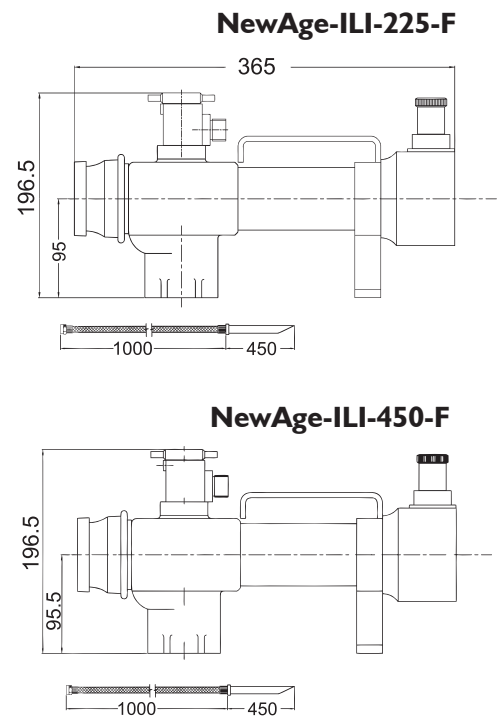
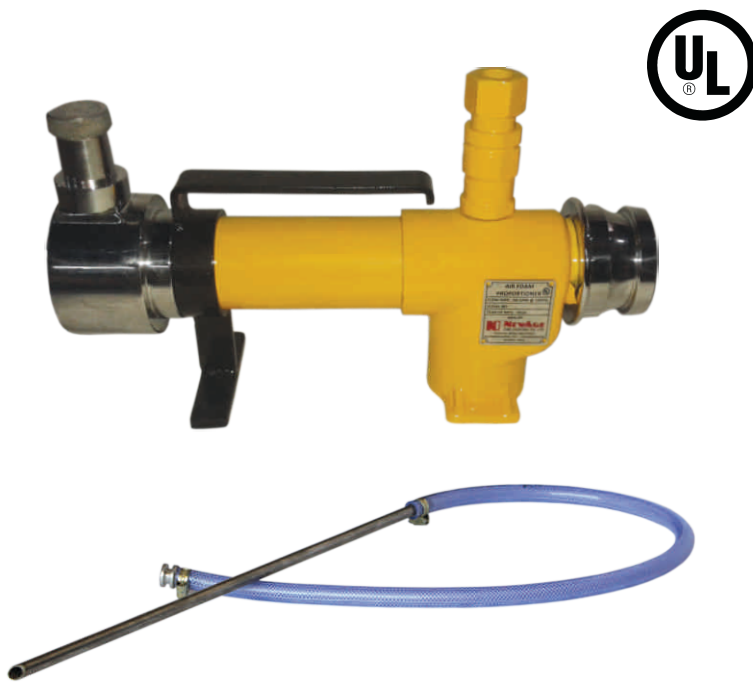

NewAge introduces improvised range of UL Listed Fixed Inline Inductors that are simple and accurate means of inducing the foam in to the water line. Designed for Fixed Induction Rates of 3 % they are compatible with NewAge UL Listed Foam Applicator Branches.

Manufactured out of Stainless Steel Grade 304, 316 and 316L, these offer superior corrosion resistance and offer proven robustness for any Fire Fighting Application in any demanding environment. Incorporating specially designed bypass mechanism, it ensures accurate foam induction and removal of back pressure. Check Valve ensures premix solution does not go into the foam container. Pick up tube assembly consists of PVC reinforced with high tensile steel wire helix flexible and non-collapsible tube with Stainless Steel Dip pipe and Strainer.

Available in the choice of 225 LPM or 450 LPM Flow Rate.

Isolation Valve optionally available. End connection are available in British Standard Instantaneous couplings, Storz Coupling, GOST Couplings, American NST, Threaded or Flanged Connections.

	NewAge-ILI-225-F	NewAge-ILI-450-F
Material of Construction	Stainless Steel 304, 316 & 316L	Stainless Steel 304, 316 & 316L
Flow Rate (GPM)	59	119
Induction	3 %	3 %
Rated Working Pressure	100 PSI	100 PSI
Pressure Range	80 PSI to 200 PSI	80 PSI to 200 PSI
Length	400 MM	400 MM
Width	95 MM	95 MM
Height	200 MM	200 MM
Approvals	UL Listed	UL Listed

www.newage-india.in

NEWAGE
FIRE FIGHTING CO. LTD.

Address : "NKB House", P. O. Box No.: 14, Mehta Market, Surendranagar - 363 001, Gujarat, India
Phone No. : +91 2752 288 000, +91 99250 63730 | **Fax :** +91 11 66173355 | **Email :** info@newage-india.in